

OWNER'S MANUAL

DPF INSPECTION TABLE

FILTERTHERM[®]



Product Record	2
Important Safety Instructions	3
Moving & Placement	4
Identifying Connections & Components	5
Inspection Table Setup	6
Installation of Display Tower	7
Basic Table Operations	8
Specifications	9
Maintenance & Troubleshooting	10
Other DPF Cleaning Equipment	10
Warranty	12
Warranty Registration	14



Copyright © 2023 - Diesel Emissions Service

All rights reserved. No part of this publication may be reproduced, distributed, or transmitted in any form or by any means, including photocopying, recording, or other electronic or mechanical methods, without the prior written permission of the publisher.

PRODUCT RECORD



Record the information from your Filtertherm® DPF Inspection Table's serial number label here for easy product reference.

Part Number:

Serial Number:

Save these instructions and your sales receipt for future reference. Use the information above to complete your Warranty Registration. You can register your Filtertherm® via online, email or fax. For email or fax, complete the registration instructions listed in the back of this manual. Register your Filtertherm® DPF Inspection Table within 45 days of purchase online to activate your warranty.

WARRANTY REGISTRATION

[web] www.filtertherm.com/warranty

[email] warranty@filtertherm.com

[fax] 530-241-0870

TECH SUPPORT

[web] www.filtertherm.com

[USA/Canada] 888-792-2922

[International] 00-1-530-241-3950

MANUFACTURED BY

Diesel Emissions Service

Redding, CA 96001

IMPORTANT SAFETY INSTRUCTIONS

READ ALL INSTRUCTIONS BEFORE INSTALLING THIS SYSTEM

WARNINGS

Soot and ash is classified as hazardous waste by some authorities. Check with local authorities. Use appropriate personal protection equipment (PPE). DPFs may be heavy, use appropriate lifting techniques and methods. Compressed air: Using non-filtered compressed air can contaminate the DPF; Use a clean source of air.



DPF INSPECTION TABLE INFO

The Filtertherm® DPF Inspection Table is an all-in-one flow restriction test and weight station. It was created to streamline and improve the efficiency and accuracy of the DPF cleaning process. This table makes it possible to conduct these tests at an ergonomic height, and allows for a more intuitive flow of the cleaning steps, which increases efficiency and accuracy. It is a robust compliment to the Filtertherm® DPF Oven.

The Filtertherm® DPF Inspection Table requires 120VAC power (outlet is a 5-20R). The flow and scale display allows you to determine the flow restriction reading and capture the weight. It comes with filter adapter rings. Also included is a USB charging port and holding shelf for your tablet.

MOVING AND PLACEMENT

- Remove the Inspection Table from the pallet
- The Inspection Table can be moved with a forklift or pallet jack
- Placement of unit should allow for easy access to the front of the unit
- Use caution. Do not damage machine while lifting.



IDENTIFY CONNECTIONS & COMPONENTS

COMPONENTS

- Flow Test port
- Scale
- Touch screen display
- Power on/off
- Wire holder
- USB charging for tablet
- Tablet holder shelf
- Adapter rings
- Power cord, 6 ft (plug not included)



FILTERTHERM®

INSPECTION TABLE SETUP

Assemble the Table

- Scale Assembly
 - Put the scale assembly in the table and level the base using the feet. The bubble level indicator is located on the base. The base should not rock.
 - Connect the data cord and tuck it out of the way.
 - Put the scale cover on the base.
- Ensure 120VAC outlet is a 5-20R
 - Consult an electrician.
- Test rotation of fan
 - The motor should rotate in the direction shown on the left side. See Basic Table Operation for running the fan.

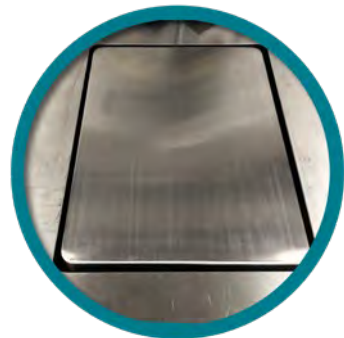
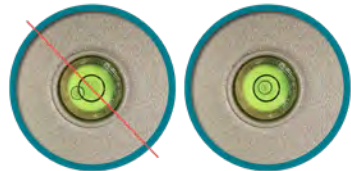

INSTALLATION OF DISPLAY TOWER

TOOLS REQUIRED:

- 7/16" wrench or socket
- #2 phillips screwdriver

- Install the display on top of the table using the hardware supplied.
- Run the cables through the wire guide.



- Plug in and lock the display cable.
- Plug in the USB cable (if tablet is being used)
- Snug the black adjustment screw on the back of the hinge.

BASIC TABLE OPERATIONS

All filters should be cool before using on the Inspection Table. Personnel should use appropriate PPE.

BEFORE DE-ASHING

- Press the Main Power button
- Place the filter on the scale, dirty side up.
- Use the wire probes to test the soot load and cell integrity
- Record the weight reading
- Press the FLOW button on screen to start the flow (Press "Fan" button to manually turn on/off the fan.)
- Place the filter on the flow test port, use adapter rings if needed, dirty side up.
- Record the flow reading



AFTER DE-ASHING; REPEAT ABOVE, THEN INSPECT

For additional info on training for DPF cleaning, see www.filtertherm.com or contact DES Directly at 888-792-2922.



Inspection & Documentation



Wire Test & Weight



Flow & De-Ash



Bake



De-Ash



Flow



Wire Test & Weight



Inspection & Documentation

SPECIFICATIONS

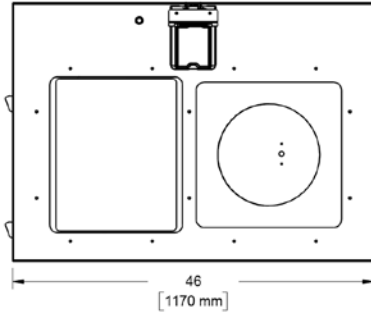
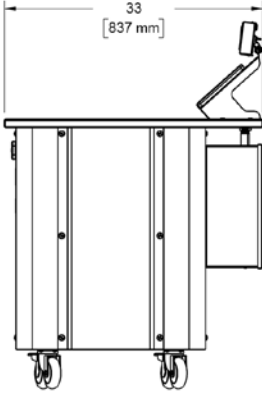

SPECIFICATIONS

ELECTRICAL REQUIREMENT: 120VAC, 5.7A

Cord supplied: 6FT (1.8m)

OVERALL DIMENSIONS: 46W X 33D X 47H in
(1170W X 840D X 1200H mm)

WEIGHT: 360lbs (163.3kg)



5-15P
Plug configuration

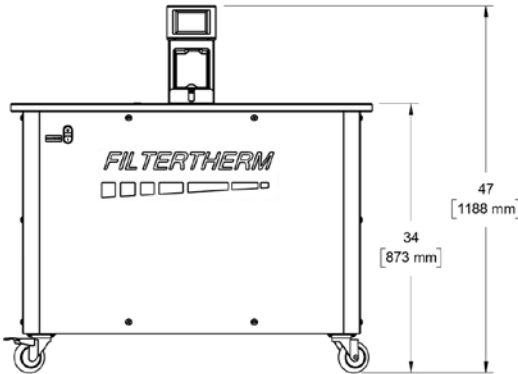

TITLE		SPECIFICATIONS FOR: FTM8003 INSPECTION TABLE	
MATERIAL			
DWG NO.		MFG100744	REV 2-0

DIESEL EMISSIONS SERVICE
17011 CLEAR CREEK RD
REDDING, CA 96001
530-241-3950
www.DES.direct

THIS DRAWING IS THE PROPERTY
OF DIESEL EMISSIONS SERVICE
(DES). THIS DRAWING MAY NOT BE
REPRODUCED OR DISCLOSED
TO A THIRD PARTY WITHOUT
WRITTEN DES PERMISSION.

MAINTENANCE & TROUBLESHOOTING

Display hinge is loose

- Tighten the black adjustment screw on the back of the hinge.

Scale does not read zero

- Remove all items from the scale
- Turn off table
- Wait 30 seconds
- Power back on



OTHER DPF CLEANING EQUIPMENT

FILTERTHERM® DPF OVEN

Like most in the industry, we used a variety of kilns over the years for our baking cycles, and we found them lacking. So we created the Filtertherm® DPF Oven. Unlike other “kilns” in the industry, our oven is specifically designed for DPF cleaning. With its Cool-Touch Technology, the outside of the unit is safe to touch while baking. It’s designed for shop applications and can accommodate multiple DPFs at once.

Our Smart-Touchscreen controls take the guess work out of DPF cleaning with pre-programmed settings for OEM and retrofit filters. The Filtertherm® DPF Oven also comes standard with settings like a temp-controlled door lock, auto shutoff for over-temp conditions and employee pass codes to lock out untrained users. Filtertherm® DPF Ovens are built to UL specifications and are proudly made in the United States.



OTHER DPF CLEANING EQUIPMENT CONT.

FILTERTHERM® DPF COOLING CART

The DPF cleaning process can quickly become time consuming. The typical time between pulling, cleaning and reinstalling a clean filter is about 24 hours. The Filtertherm® DPF Thermal Regeneration System is specifically designed to streamline this process and reduce downtime. Waiting for hot filters to cool costs you valuable time. Solution? The Filtertherm® DPF Cooling Cart.

Our cooling cart decreases the cooling time by 2 - 4 hours (depending on environment), allowing your shop to reduce downtime and increase productivity. The Filtertherm® DPF Cooling Cart is designed to cool hot filters before and after the cleaning process, is simple to operate and is a robust complement to the rest of the Filtertherm® DPF Thermal Regeneration System.



***FILTER*TRAK® DPF TRACKING SOFTWARE**

FILTERtrak® is "the Diesel Market's Premier DPF Service Tracking Application". DES saw the need in California for an efficient way to track DPF cleanings to meet the state's strict CARB standards. FILTERtrak® stores pictures, vehicle information, filter information, cleaning records and more. It is now offered across the United States and Canada. It is completely scalable, from the largest DPF cleaning facilities to one-man shops. Filtertrak® is a must-have tool for anyone in the DPF cleaning business!



Diesel Emissions Service ("Seller") warrants to the original purchaser of the Filtertherm® Thermal Regeneration System ("product"), subject to all of the terms and conditions hereof, that the Product and all components thereof will be free from defects in materials and workmanship for the following period(s) of time, measured from the date of purchase:



Diesel Emissions Service warrants the Filtertherm® Thermal Regeneration System for a period of ONE (1) YEAR.

Seller's obligation under this warranty is specifically limited to repairing or replacing, at its option, the product or any part thereof which is determined by Seller to be defective during the applicable warranty period.

This warranty gives you specific legal rights, and you may also have other rights which vary from state to state. This warranty is made to the original purchaser of the Product only, and is not transferable or assignable. This warranty applies only to components of the Filtertherm® system. This warranty does not apply to any unauthorized or improper installation, alteration or repair of the Product, or to any Product or component which has been damaged or deteriorated due to misuse, neglect, accident, failure to provide necessary maintenance, normal wear and tear, or acts of God or any other cause beyond the reasonable control of Seller, missing or damaged parts due to clearance, repairs, and maintenance to components.

ALL EXPRESS AND IMPLIED WARRANTIES FOR THE PRODUCT, INCLUDING BUT NOT LIMITED TO ANY IMPLIED WARRANTIES OF MERCHANTABILITY AND FITNESS FOR A PARTICULAR PURPOSE, ARE LIMITED IN TIME TO THE APPLICABLE WARRANTY PERIOD REFLECTED ABOVE. NO WARRANTIES, WHETHER EXPRESS OR IMPLIED, WILL APPLY AFTER THE LIMITED WARRANTY PERIOD HAS EXPIRED.

Some states do not allow limitations on how long an implied warranty lasts. **IN NO EVENT SHALL DIESEL EMISSIONS SERVICE OR ITS AFFILIATES BE RESPONSIBLE FOR, OR LIABLE TO ANYONE FOR, SPECIAL, INDIRECT, COLLATERAL, PUNITIVE, INCIDENTAL OR CONSEQUENTIAL DAMAGES**, even if Seller has been advised of the possibility of such damages. Such excluded damages include, but are not limited to, loss of use, cost of any substitute product, or other similar indirect financial loss. Some states do not allow the exclusion or limitation of incidental or consequential damages. Claims under this warranty must be made promptly after discovery and within the applicable warranty period.

To obtain warranty service, you must contact DIESEL EMISSIONS SERVICE customer service and provide proof of the date and location of purchase and identification as the original purchaser. Call (DES) Customer Service toll free at 1-888-792-2922 to speak with a trained representative.

Purchaser must allow seller a reasonable opportunity to inspect Product claimed to be defective prior to removal or alteration of its condition. Upon determination by Seller that the Product or any part thereof is defective during the applicable warranty period (which may require purchaser to return the Product to Seller at purchaser's expense), Seller will supply the purchaser with replacement parts or, at its option, a replacement Product. Seller may use new or reconditioned parts, or a new or reconditioned Product of the same or similar design.

PURCHASER'S WARRANTY RESPONSIBILITY

- Warranty form submitted within 45 days of purchase - submit online, fax or email
- Detailed description of failure
- Pictures of failure
- Contact *Diesel Emissions Service* within 24 hours of failure

Complete registration and return via email, fax, mail or online (at www.filtertherm.com/warranty) within 45 days of purchase to activate your warranty.

Name**Email Address****Company Name****Phone Number****Address****Model Name****Address 2****Serial Number****City****Date of Purchase****State****Dealer Purchased From****Zip****Date of Installation**

FILTERTHERM® DPF OVEN

THE INDUSTRY'S FIRST "SMART TOUCHSCREEN"



Autoselects correct temperature profile for single or multiple filters



Manufacturer-Approved Temperature Profiles with Safe & Effective Ramp Rates



Temperature-Controlled Auto Door Lock



Multiple Sizes & Power Options Available



Powder-Coated for Durability



Employee Pass Codes Lock Out Untrained Users



Pre-Programmed for all DPF Substrates



On-Screen Operator's Manual & Training Aids



Auto Shutoff for Over-Temp Conditions



High-Voltage Plug & Receptacle Included

WWW.FILTERTHERM.COM

888-792-2922

INFO@FILTERTHERM.COM